

**NPN SILICON PLANAR EPITAXIAL TRANSISTORS**

**2N3704 2N3705**

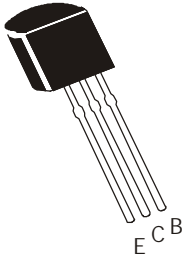

**TO-92  
Plastic Package**

For Lead Free Parts, Device Part #  
will be Prefixed with "T"

Amplifier Transistor

**ABSOLUTE MAXIMUM RATINGS (T<sub>a</sub>=25°C)**

| DESCRIPTION                                      | SYMBOL                            | 2N3704       | 2N3705 | UNIT  |
|--|-----------------------------------|--------------|--------|-------|
| Collector Emitter Voltage                        | V <sub>CEO</sub>                  | 30           |        | V     |
| Collector Base Voltage                           | V <sub>CBO</sub>                  | 50           |        | V     |
| Emitter Base Voltage                             | V <sub>EBO</sub>                  | 5.0          |        | V     |
| Collector Current Continuous                     | I <sub>C</sub>                    | 600          |        | mA    |
| Total Device Dissipation at T <sub>a</sub> =25°C | P <sub>D</sub>                    | 625          |        | mW    |
| Derate Above 25°C                                |                                   | 5.0          |        | mW/°C |
| Operating And Storage Junction Temperature Range | T <sub>j</sub> , T <sub>stg</sub> | - 55 to +150 |        | °C    |

**THERMAL RESISTANCE**

|                                 |                      |     |      |
|---------------------------------|----------------------|-----|------|
| Junction to Ambient in free air | R <sub>th(j-a)</sub> | 200 | °C/W |
|---------------------------------|----------------------|-----|------|

**ELECTRICAL CHARACTERISTICS (T<sub>a</sub>=25°C unless specified otherwise)**

| DESCRIPTION                          | SYMBOL                | TEST CONDITION                             | MIN    | MAX | UNIT |
|--------------------------------------|-----------------------|--|--------|-----|------|
| Collector Emitter Voltage            | V <sub>CEO</sub>      | I <sub>C</sub> =1mA, I <sub>B</sub> =0     | 30     |     | V    |
| Collector Base Voltage               | V <sub>CBO</sub>      | I <sub>C</sub> =100µA, I <sub>E</sub> =0   | 50     |     | V    |
| Emitter Base Voltage                 | V <sub>EBO</sub>      | I <sub>E</sub> =100µA, I <sub>C</sub> =0   | 5.0    |     | V    |
| DC Current Gain                      | *h <sub>FE</sub>      | V <sub>CE</sub> =2V, I <sub>C</sub> =50mA  | 2N3704 | 100 | 300  |
|                                      |                       |  | 2N3705 | 50  | 150  |
| Collector Cut Off Current            | I <sub>CBO</sub>      | V <sub>CB</sub> =20V, I <sub>E</sub> =0    |        | 100 | nA   |
| Emitter Cut Off Current              | I <sub>EBO</sub>      | V <sub>EB</sub> =3V, I <sub>C</sub> =0     |        | 100 | nA   |
| Collector Emitter Saturation Voltage | *V <sub>CE(sat)</sub> | I <sub>C</sub> =100mA, I <sub>B</sub> =5mA | 2N3704 | 0.6 | V    |
|                                      |                       |  | 2N3705 | 0.8 | V    |
| Base Emitter (On) Voltage            | *V <sub>BE(on)</sub>  | I <sub>C</sub> =100mA, V <sub>CE</sub> =2V | 0.5    | 1.0 | V    |

**DYNAMIC CHARACTERISTICS**

| DESCRIPTION           | SYMBOL          | TEST CONDITION                                     | MIN | MAX | UNIT |
|-----------------------|-----------------|--|-----|-----|------|
| Transistors Frequency | f <sub>T</sub>  | I <sub>C</sub> =50mA, V <sub>CE</sub> =2V, f=20MHz | 100 |     | MHz  |
| Output Capacitance    | C <sub>ob</sub> | I <sub>E</sub> =0, V <sub>CB</sub> =10V, f=1MHz    |     | 12  | pF   |

\*Pulse Test: Pulse Width ≤ 300µs, Duty Cycle ≤ 2%

2N3704\_2N3705Rev\_1 081205E

**TO-92  
Plastic Package**

For Lead Free Parts, Device Part #  
will be Prefixed with "T"

**TO-92 Plastic Package**

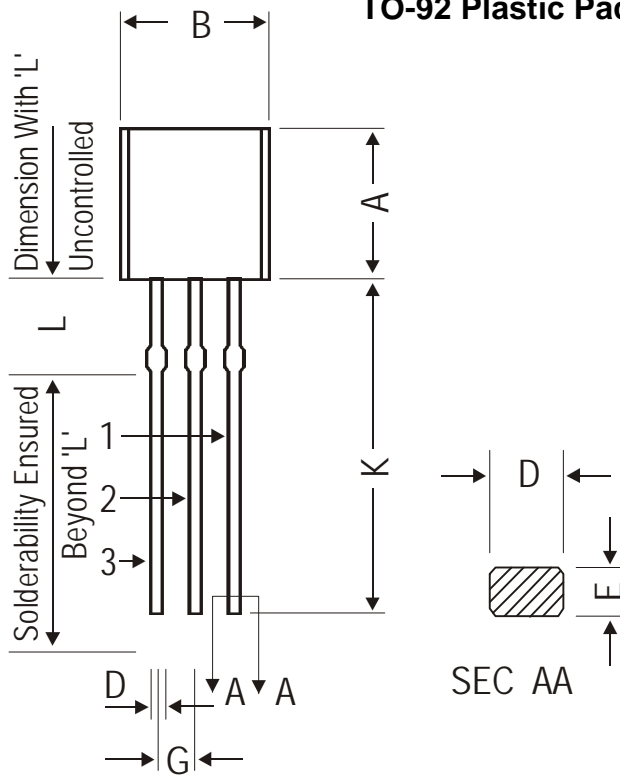

| DIM | MIN.  | MAX.  |
|-----|-------|-------|
| A   | 4.32  | 5.33  |
| B   | 4.45  | 5.20  |
| C   | 3.18  | 4.19  |
| D   | 0.41  | 0.55  |
| E   | 0.35  | 0.50  |
| F   | 5 DEG |       |
| G   | 1.14  | 1.40  |
| H   | 1.20  | 1.40  |
| K   | 12.70 | —     |
| L   | 1.982 | 2.082 |
| M   | 1.03  | 1.20  |

All dimensions are in mm

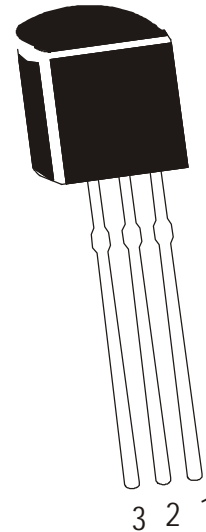
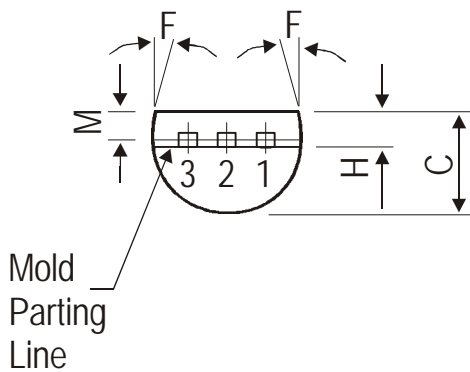

**PIN CONFIGURATION**

1. BASE
2. COLLECTOR
3. EMITTER

The TO-92 Package, Tape and Ammo Pack Drawings are correct as on the date of issue/revision of this Data Sheet.

The currently valid dimensions and information, may please be confirmed from the TO-92 Drawing in the Packages and Packing Section of the Product Catalogue.

**Packing Details**

| PACKAGE    | STANDARD PACK |                | INNER CARTON BOX  |     | OUTER CARTON BOX  |     |          |
|------------|---------------|----------------|-------------------|-----|-------------------|-----|----------|
|            | Details       | Net Weight/Qty | Size              | Qty | Size              | Qty | Gr Wt    |
| TO-92 Bulk | 1K/polybag    | 200 gm/1K pcs  | 3" x 7.5" x 7.5"  | 5K  | 17" x 15" x 13.5" | 80K | 23 kgs   |
| TO-92 T&A  | 2K/ammo box   | 645 gm/2K pcs  | 12.5" x 8" x 1.8" | 2K  | 17" x 15" x 13.5" | 32K | 12.5 kgs |

2N3704\_2N3705Rev\_1 081205E

**TO-92  
Plastic Package**

For Lead Free Parts, Device Part #  
will be Prefixed with "T"

**TO-92 Tape and Ammo Pack**

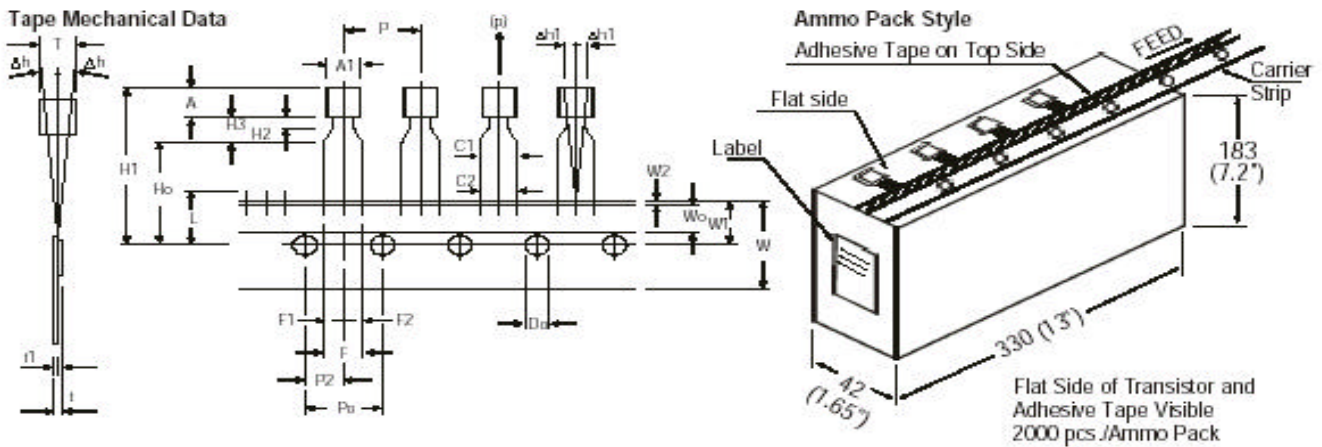

All dimensions are in mm

| ITEM                                    | SYMBOL  | SPECIFICATION |      |      |                |
|---|---------|---------------|------|------|----------------|
|   |         | MIN.          | NOM. | MAX. | TOL.           |
| BODY WIDTH                              | A1      | 4.45          |      | 5.20 |                |
| BODY HEIGHT                             | A       | 4.32          |      | 5.33 |                |
| BODY THICKNESS                          | T       | 3.18          |      | 4.19 |                |
| PITCH OF COMPONENT                      | P       |               | 12.7 |      | ± 1.0          |
| *1 FEED HOLE PITCH                      | Po      |               | 12.7 |      | ± 0.3          |
| *2 FEED HOLE CENTRE TO COMPONENT CENTRE | P2      |               | 6.35 |      | ± 0.4          |
| DISTANCE BETWEEN OUTER LEADS            | F       |               | 5.08 |      | + 0.6<br>- 0.2 |
| *3 COMPONENT ALIGNMENT SIDE VIEW        | Δh      |               | 0    | 1.0  |                |
| *4 COMPONENT ALIGNMENT FRONT VIEW       | Δh1     |               | 0    | 1.3  |                |
| TAPE WIDTH                              | W       |               | 18   |      | ± 0.5          |
| HOLD-DOWN TAPE WIDTH                    | W0      |               | 6    |      | ± 0.2          |
| HOLE POSITION                           | W1      |               | 9    |      | + 0.7<br>- 0.5 |
| HOLD-DOWN TAPE POSITION                 | W2      | 0.0           |      | 0.7  |                |
| LEAD WIRE CLINCH HEIGHT                 | Ho      |               | 16   |      | ± 0.5          |
| COMPONENT HEIGHT                        | H1      |               |      | 24.0 |                |
| LENGTH OF SNIPPED LEADS                 | L       |               |      | 11.0 |                |
| FEED HOLE DIAMETER                      | Do      |               | 4    |      | ± 0.2          |
| *5 TOTAL TAPE THICKNESS                 | t       |               |      | 1.2  |                |
| LEAD - TO - LEAD DISTANCE               | F1, F2  | 2.40          |      | 2.70 | - 0.1          |
| STAND OFF                               | H2      | 0.45          |      | 1.45 |                |
| CLINCH HEIGHT                           | H3      |               |      | 3.0  |                |
| LEAD PARALLELISM                        | C1 - C2 |               |      | 0.22 |                |
| PULL - OUT FORCE                        | (p)     |               | 6N   |      |                |

**NOTES**

1. Maximum alignment deviation between leads will not to be greater than 0.2mm.
2. Maximum non-cumulative variation between tape feed holes shall not exceed 1 mm in 20 pitches.
3. Holddown tape will not exceed beyond the edge(s) of carrier tape and there shall be no exposure of adhesive.
4. There will be no more than three (3) consecutive missing components in a tape.
5. A tape trailer, having at least three feed holes are provided after the last component in a tape.
6. Splices should not interfere with the sprocket feed holes.

**REMARKS**

- \*1 Cumulative pitch error 1.0 mm/20 pitch
- \*2 To be measured at bottom of clinch
- \*3 At top of body
- \*4 At top of body
- \*5 t1 0.3 - 0.6 mm

**Component Disposal Instructions**

1. CDIL Semiconductor Devices are RoHS compliant, customers are requested to please dispose as per prevailing Environmental Legislation of their Country.
2. In Europe, please dispose as per EU Directive 2002/96/EC on Waste Electrical and Electronic Equipment (WEEE).

**TO-92  
Plastic Package**

For Lead Free Parts, Device Part #  
will be Prefixed with "T"

**Disclaimer**

The product information and the selection guides facilitate selection of the CDIL's Semiconductor Device(s) best suited for application in your product(s) as per your requirement. It is recommended that you completely review our Data Sheet(s) so as to confirm that the Device(s) meet functionality parameters for your application. The information furnished in the Data Sheet and on the CDIL Web Site/CD are believed to be accurate and reliable. CDIL however, does not assume responsibility for inaccuracies or incomplete information. Furthermore, CDIL does not assume liability whatsoever, arising out of the application or use of any CDIL product; neither does it convey any license under its patent rights nor rights of others. These products are not designed for use in life saving/support appliances or systems. CDIL customers selling these products (either as individual Semiconductor Devices or incorporated in their end products), in any life saving/support appliances or systems or applications do so at their own risk and CDIL will not be responsible for any damages resulting from such sale(s).

CDIL strives for continuous improvement and reserves the right to change the specifications of its products without prior notice.



CDIL is a registered Trademark of  
Continental Device India Limited

C-120 Naraina Industrial Area, New Delhi 110 028, India.

Telephone + 91-11-2579 6150, 4141 1112, Fax + 91-11-2579 5290, 4141 1119

email@cdil.com www.cdilsemi.com