

**2 × 6 W Hi-fi stereo power amplifier**

**TDA1517P/TDA1517S**

**FEATURES**

- Requires very few external components
- High output power
- Fixed gain
- Good ripple rejection
- Mute/standby switch
- AC and DC short-circuit safe to ground and  $V_P$
- Thermally protected
- Meet the **Hi-Fi** audio performance
- Capability to handle high energy on outputs ( $V_P = 0\text{ V}$ )
- Almost no switch-on/switch-off pop noise
- Electrostatic discharge protection.

**GENERAL DESCRIPTION**

The BM TDA1517P is an integrated class-AB dual output amplifier in a plastic DIP18 power package. It can delivery 2\*6W with a great low Iq standby mode. The device is primarily designed for LCD-TV, monitor and for multi-media AV center **Hi-Fi** applications.

TDA1517P is DIP18 package , TDA1517S is HSOP28 pacakge.

**QUICK REFERENCE DATA**

SYMBOL	PARAMETER	CONDITIONS	MIN.	TYP.	MAX.	UNIT
$V_P$	supply voltage		6.0	14.4	18.0	V
$I_{ORM}$	repetitive peak output current		–	–	2.5	A
$I_{q(tot)}$	total quiescent current		–	40	80	mA
$I_{sb}$	standby current		–	0.1	100	$\mu\text{A}$
$I_{sw}$	switch-on current		–	–	40	$\mu\text{A}$
$ Z_i $	input impedance		50	–	–	$\text{k}\Omega$
$P_o$	output power	$R_L = 4\ \Omega$ ; THD = 0.5%	–	5	–	W
		$R_L = 4\ \Omega$ ; THD = 10%	–	6	–	W
SVRR	supply voltage ripple rejection	$f_i = 100\ \text{Hz}$ to 10 kHz	48	–	–	dB
$\alpha_{cs}$	channel separation		40	–	–	dB
$G_v$	closed loop voltage gain		19	20	21	dB
$V_{no(rms)}$	noise output voltage (RMS value)		–	50	–	$\mu\text{V}$
$T_c$	crystal temperature		–	–	150	$^{\circ}\text{C}$

Notes: Not only the Signal to Noise(S/N), also the Frequency Response(FR), the **Hi-Fi** BM-TDA1517P is much better than SL1517 and YD1517, and the switch on-off pop noise is lowest, which the performance customer can verify ! It can pin to pin replace YD1517 and SL1517 or D1517 without changing PCB or external.

BLOCK DIAGRAM

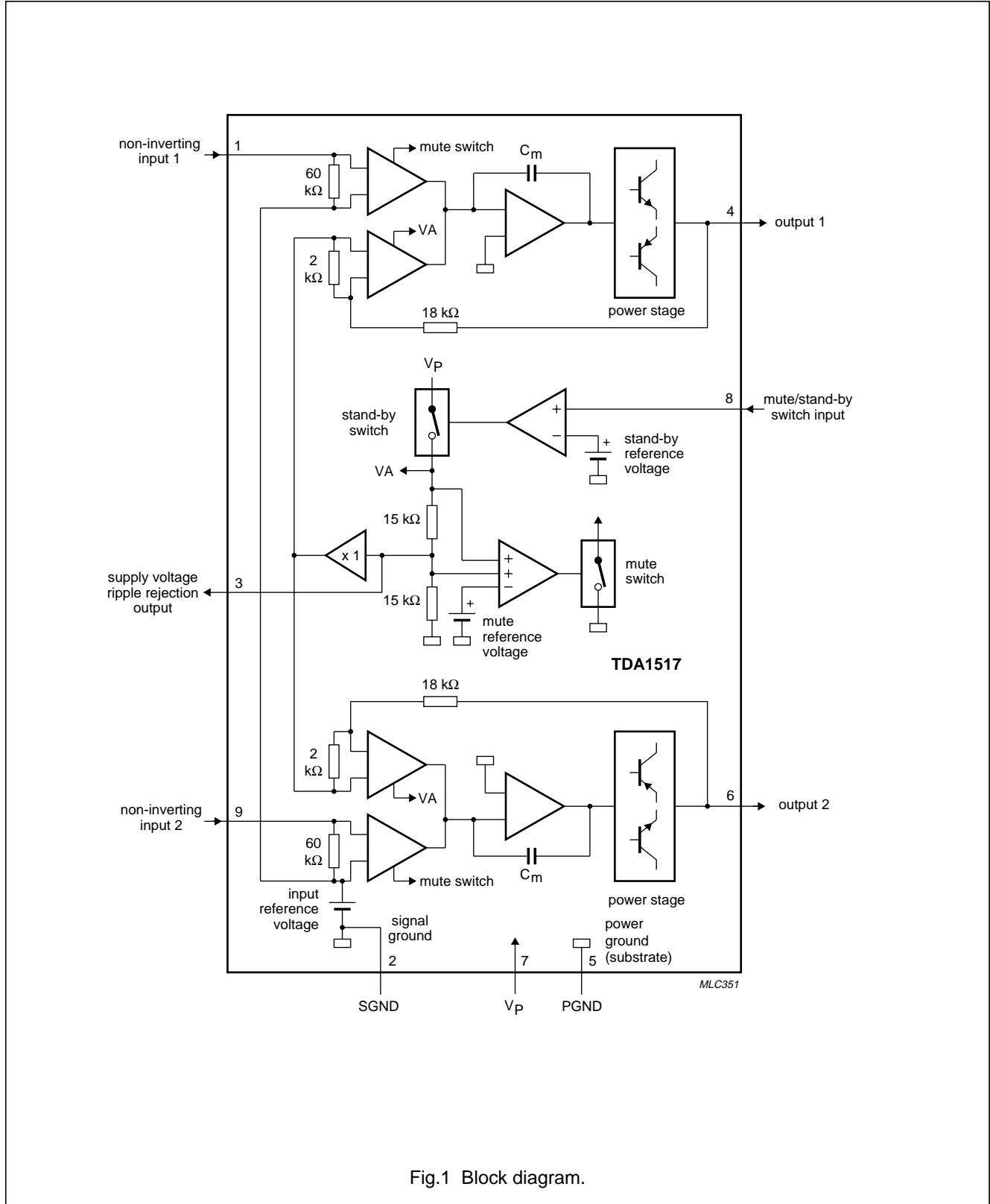
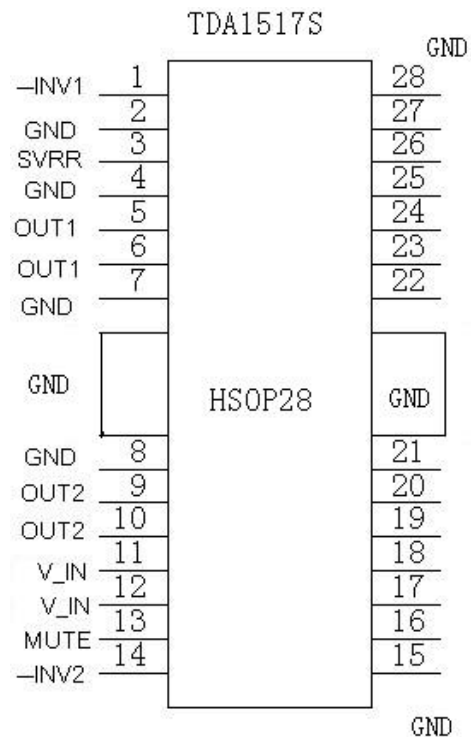
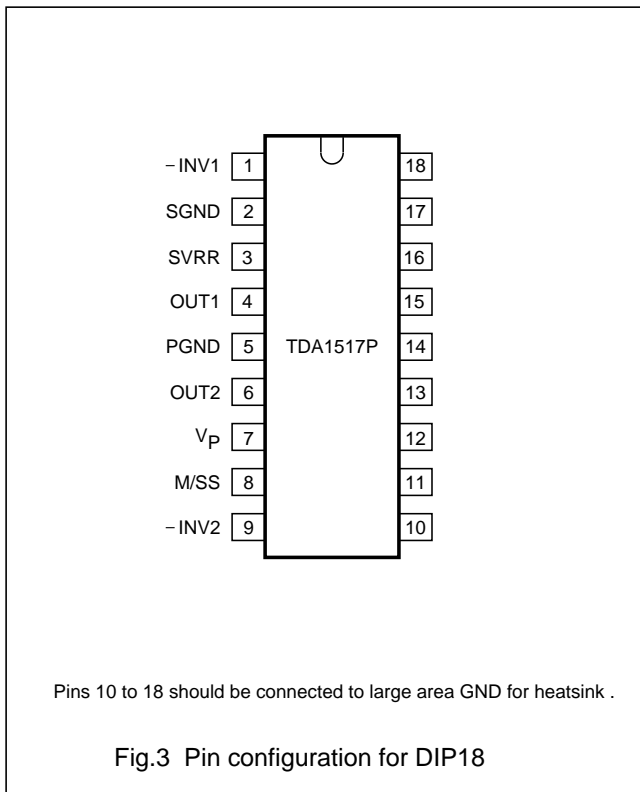

Fig.1 Block diagram.

**PINNING**

	DIP18(HSOP28) PIN	DESCRIPTION
-INV1	1 (1)	input 1
SGND	2 (2,4)	signal ground
SVRR	3 (3)	supply voltage ripple rejection output
OUT1	4 (5,6)	output 1
PGND	5 (7,8)	power ground
OUT2	6 (9,10)	output 2
V <sub>P</sub>	7 (11,12)	supply voltage
M/SS	8 (13)	mute/standby switch input
-INV2	9 (14)	input 2



**FUNCTIONAL DESCRIPTION**

The TDA1517 contains two identical amplifiers with differential input stages. The gain of each amplifier is fixed at 20 dB. A special feature of the device is the mute/standby switch which has the following features:

- Low standby current (<100 μA)
- Low mute/standby switching current (low cost supply switch)
- Mute condition.

## 2 × 6 W stereo power amplifier

TDA1517

**LIMITING VALUES**

In accordance with the Absolute Maximum Rating System .

SYMBOL	PARAMETER	CONDITIONS	MIN.	MAX.	UNIT
$V_P$	supply voltage		–	18	V
$V_{P(sc)}$	AC and DC short-circuit safe voltage		–	18	V
$V_{P(r)}$	reverse polarity		–	6	V
$ERG_O$	energy handling capability at outputs	$V_P = 0\text{ V}$	–	200	mJ
$I_{OSM}$	non-repetitive peak output current		–	4	A
$I_{ORM}$	repetitive peak output current		–	2.5	A
$P_{tot}$	total power dissipation	see Fig.4	–	15	W
$T_{stg}$	storage temperature		–45	+150	°C
$T_{amb}$	operating ambient temperature		–20	+85	°C
$T_c$	crystal temperature		–	150	°C

**THERMAL RESISTANCE**

SYMBOL	TYPE NUMBER	PARAMETER	VALUE	UNIT
$R_{th\ j-c}$	TDA1517	thermal resistance from junction to case	8	K/W
$R_{th\ j-p}$	TDA1517	thermal resistance from junction to pins	15	K/W
$R_{th\ j-a}$	TDA1517	thermal resistance from junction to ambient	50	K/W

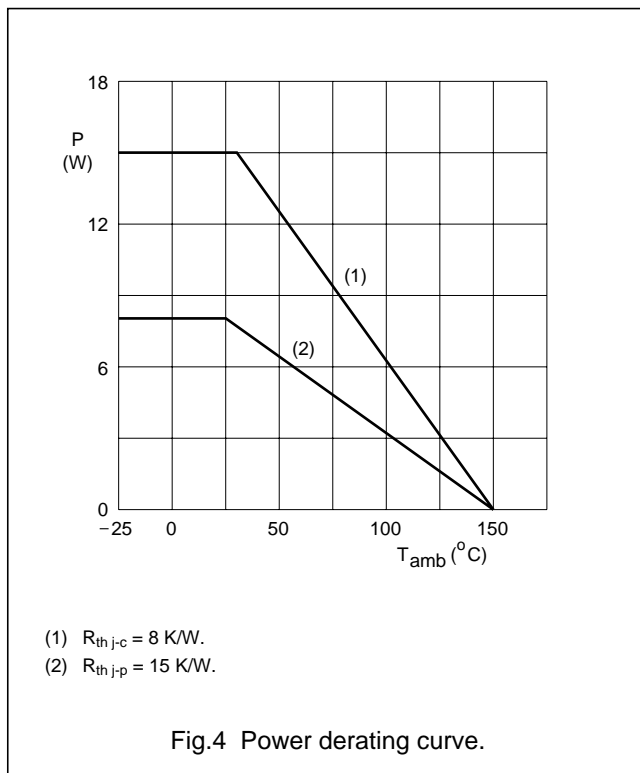

**2 × 6 W stereo power amplifier****TDA1517****DC CHARACTERISTICS** $V_P = 14.4\text{ V}$ ;  $T_{\text{amb}} = 25\text{ °C}$ ; measured in Fig.6; unless otherwise specified.

SYMBOL	PARAMETER	CONDITIONS	MIN.	TYP.	MAX.	UNIT
<b>Supply</b>						
$V_P$	supply voltage	note 1	6.0	14.4	18.0	V
$I_{q(\text{tot})}$	total quiescent current		–	40	80	mA
$V_O$	DC output voltage		–	6.95	–	V
<b>Mute/standby switch</b>						
$V_8$	switch-on voltage level	see Fig.5	8.5	–	–	V
<b>Mute condition</b>						
$V_O$	output signal in mute position	$V_{l(\text{max})} = 1\text{ V}$ ; $f_i = 20\text{ Hz to }15\text{ kHz}$	–	–	2	mV
<b>Standby condition</b>						
$I_{\text{sb}}$	DC current in standby condition		–	–	100	$\mu\text{A}$
$V_{\text{sw}}$	switch-on current		–	12	40	$\mu\text{A}$

**Note**

1. The circuit is DC adjusted at  $V_P = 6\text{ to }18\text{ V}$  and AC operating at  $V_P = 8.5\text{ to }18\text{ V}$ .

**2 × 6 W stereo power amplifier****TDA1517****AC CHARACTERISTICS** $V_P = 14.4\text{ V}$ ;  $R_L = 4\ \Omega$ ;  $f = 1\text{ kHz}$ ;  $T_{\text{amb}} = 25\text{ °C}$ ; measured in Fig.6; unless otherwise specified.

SYMBOL	PARAMETER	CONDITIONS	MIN.	TYP.	MAX.	UNIT
$P_o$	output power	THD = 0.5%; note 1	4	5	–	W
		THD = 10%; note 1	5.5	6.0	–	W
THD	total harmonic distortion	$P_o = 1\text{ W}$	–	0.1	–	%
$f_{lr}$	low frequency roll-off	at –3 dB; note 2	–	45	–	Hz
$f_{hr}$	high frequency roll-off	at –1 dB	20	–	–	kHz
$G_v$	closed loop voltage gain		19	20	21	dB
SVRR	supply voltage ripple rejection	note 3				
	on		48	–	–	dB
	mute		48	–	–	dB
	standby		80	–	–	dB
$ Z_i $	input impedance		50	60	75	k $\Omega$
$V_{no}$	noise output voltage					
	on	$R_s = 0\ \Omega$ ; note 4	–	50	–	$\mu\text{V}$
	on	$R_s = 10\ \Omega$ ; note 4	–	70	100	$\mu\text{V}$
	mute	note 5	–	50	–	$\mu\text{V}$
$\alpha_{cs}$	channel separation	$R_s = 10\ \Omega$	40	–	–	dB
$ \Delta G_v $	channel unbalance		–	0.1	1	dB

**Notes**

1. Output power is measured directly at the output pins of the IC.
2. Frequency response externally fixed.
3. Ripple rejection measured at the output with a source impedance of 0  $\Omega$ , maximum ripple amplitude of 2 V (p-p) and a frequency between 100 Hz and 10 kHz.
4. Noise voltage measured in a bandwidth of 20 Hz to 20 kHz.
5. Noise output voltage independent of  $R_s$  ( $V_i = 0\text{ V}$ ).

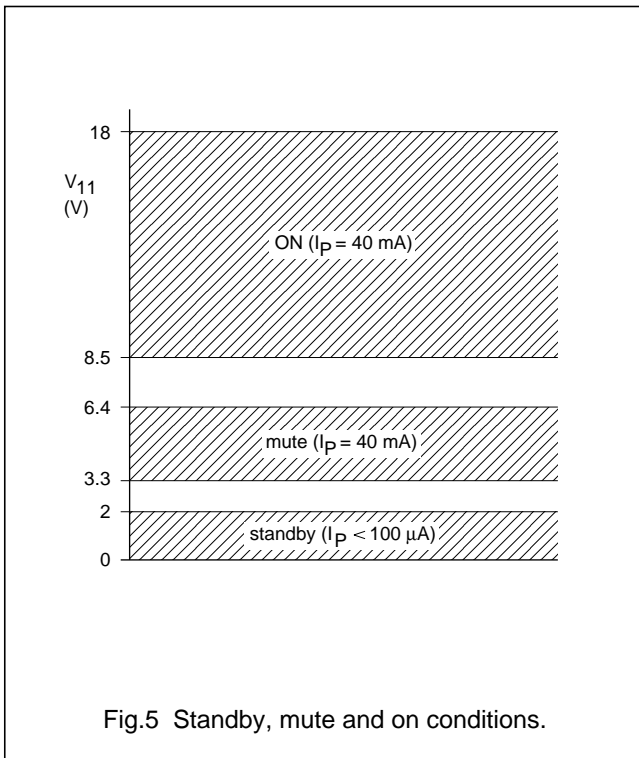

APPLICATION INFORMATION

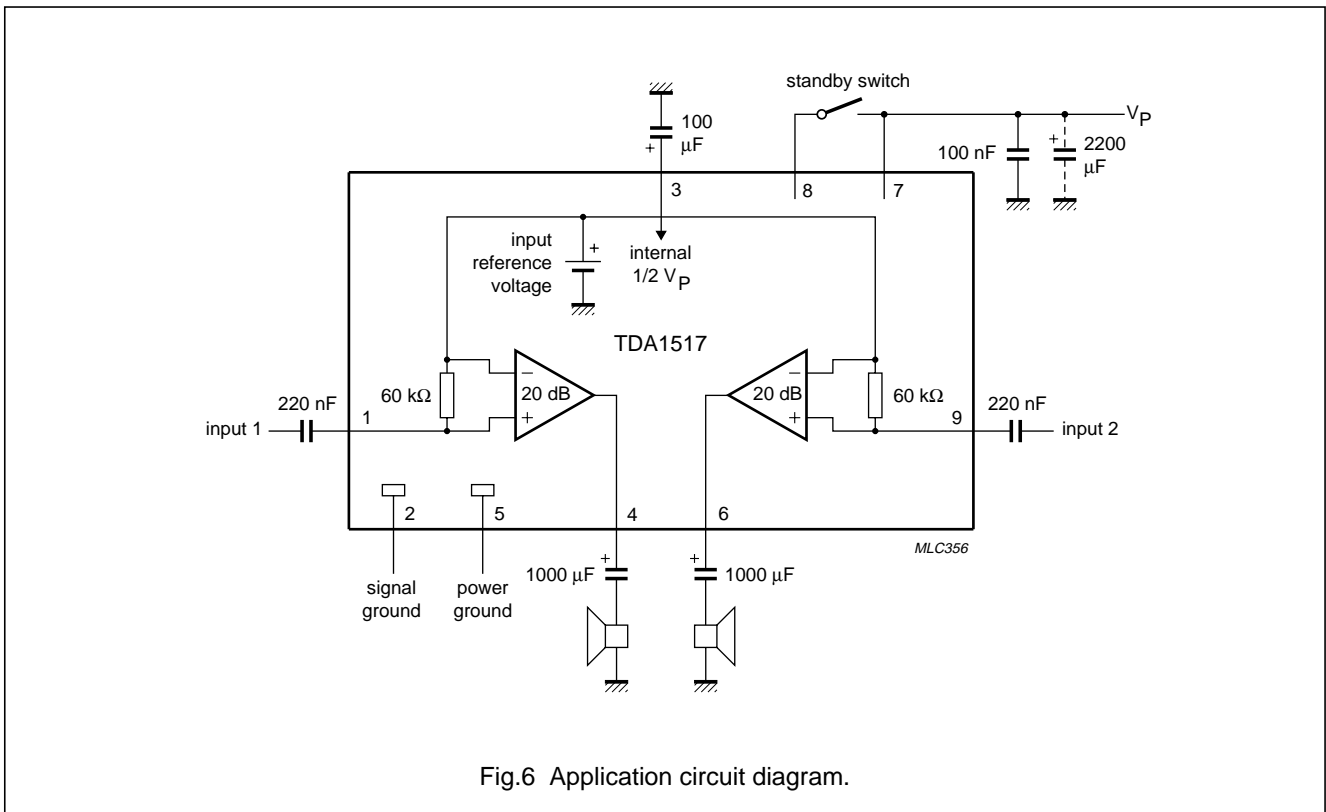

DIP18: plastic heat-dissipating dual in-line package; 18 leads

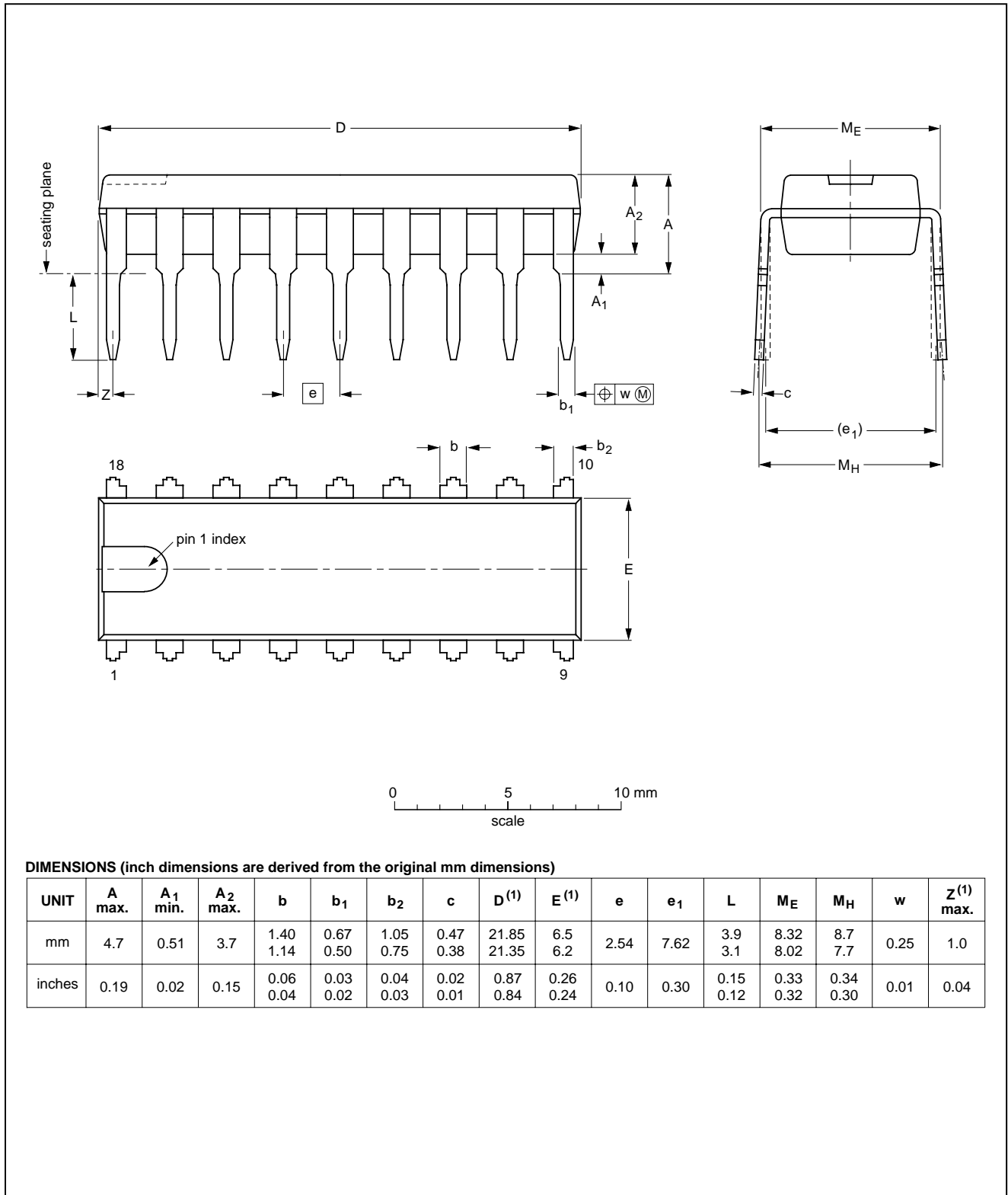



HSOP28 package outline size

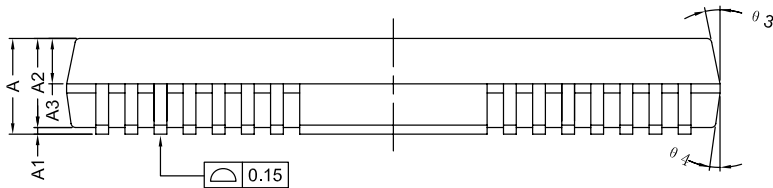
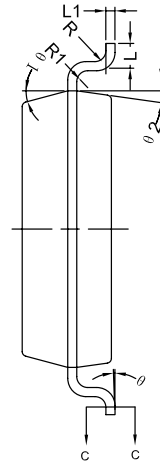
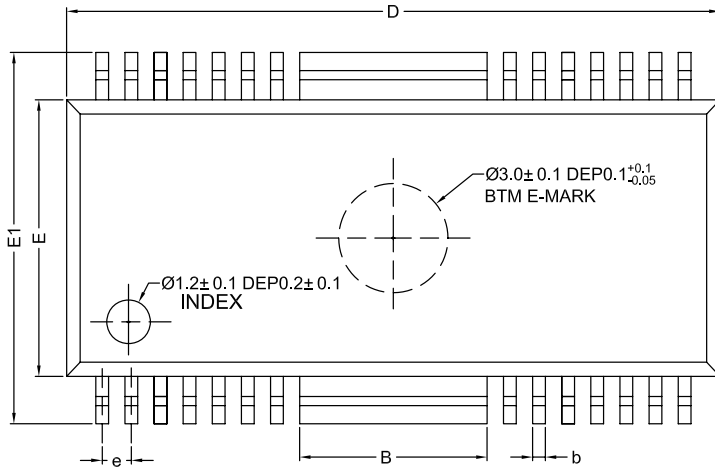

COMMON DIMENSIONS  
(UNITS OF MEASURE=MILLIMETER)

SYMBOL	MIN	NOM	MAX
A	2.35	2.55	2.75
A1	0	-	0.25
A2	2.35	2.45	2.55
A3	1.15	1.25	1.35
B	5.00	5.15	5.30
b	0.31	-	0.44
b1	0.30	0.35	0.40
c	0.21	-	0.34
c1	0.20	0.25	0.30
D	17.85	17.95	18.05
E	7.50	7.60	7.70
E1	10.00	-	10.60
e	0.70	0.80	0.90
L	0.50	0.65	0.80
L1	0.25BSC		
R	0.10	-	-
R1	0.10	-	-
θ	0°	-	8°
θ 1	13°	15°	17°
θ 2	6°	8°	10°
θ 3	9.5°	11.5°	13.5°
θ 4	6°	8°	10°

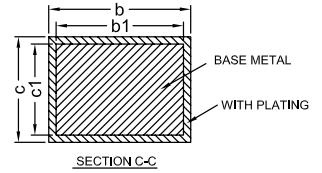

NOTES:  
ALL DIMENSIONS DO NOT INCLUDE MOLD FLASH OR PROTRUSIONS.